

ASPHALT FLOAT

ST 160 - 200

Up to 10 times faster than manual work.



WE DESIGN
CUSTOMER SATISFACTION.

- ✔ SIMEX asphalt floats are easy to use and offer the advantage of **CONSIDERABLE SAVINGS OFF MANUFACTURING COSTS**. They allow manual labour to be replaced effectively, rapidly and in a cleaner, more consistent manner.
- ✔ These asphalt floats have been designed without a tank for the material. This means **NOT HAVING ANYTHING DIFFICULT TO CLEAN**, or heavy to carry. The only thing to do is to place material in front of the float to carry out a skilful job (up to 10 times more quickly than with manual labour).
- ✔ The Simex asphalt float is the result of innovative design mainly focussing on straight forward construction and user-friendliness. For this reason, it offers all the advantages of easy-to-use equipment:
 - EASY TO BECOME FAMILIAR WITH
 - EASY TO USE
 - EASY TO CLEAN
 - STURDY
- ✔ The Simex asphalt float is a smart piece of equipment: just the thing for a smart company.

- ❶ **DEVICE ALLOWING OPERATION OUTSIDE OF YOUR PRIME MOVER PROFILE:** mechanical or (optionally) hydraulic, to spread asphalt up to a width of 1700 mm on the outside of the wheels.
- ❷ **MATERIAL CONVEYING SIDE BOARDS,** hydraulically controlled and equipped with a mechanical device for inclination opening/closing ❷ .
- ❸ **SIDE SHIFT:** mechanically controlled for perfect adhesion to the ground.
- ❹ **GRADER BLADE:** mechanical ❸ or (optional) electrical adjustment to set/adjust the thickness of material to leave on the ground for final compacting.
- ❺ **CONTROL PANEL:** portable or cable-controlled for closer inspection of the work being carried out to guarantee even more accurate results.
- ❻ (optional) material **CONTAINMENT BOARD,** to use when working outside of the machine profile (on either side of your prime mover).

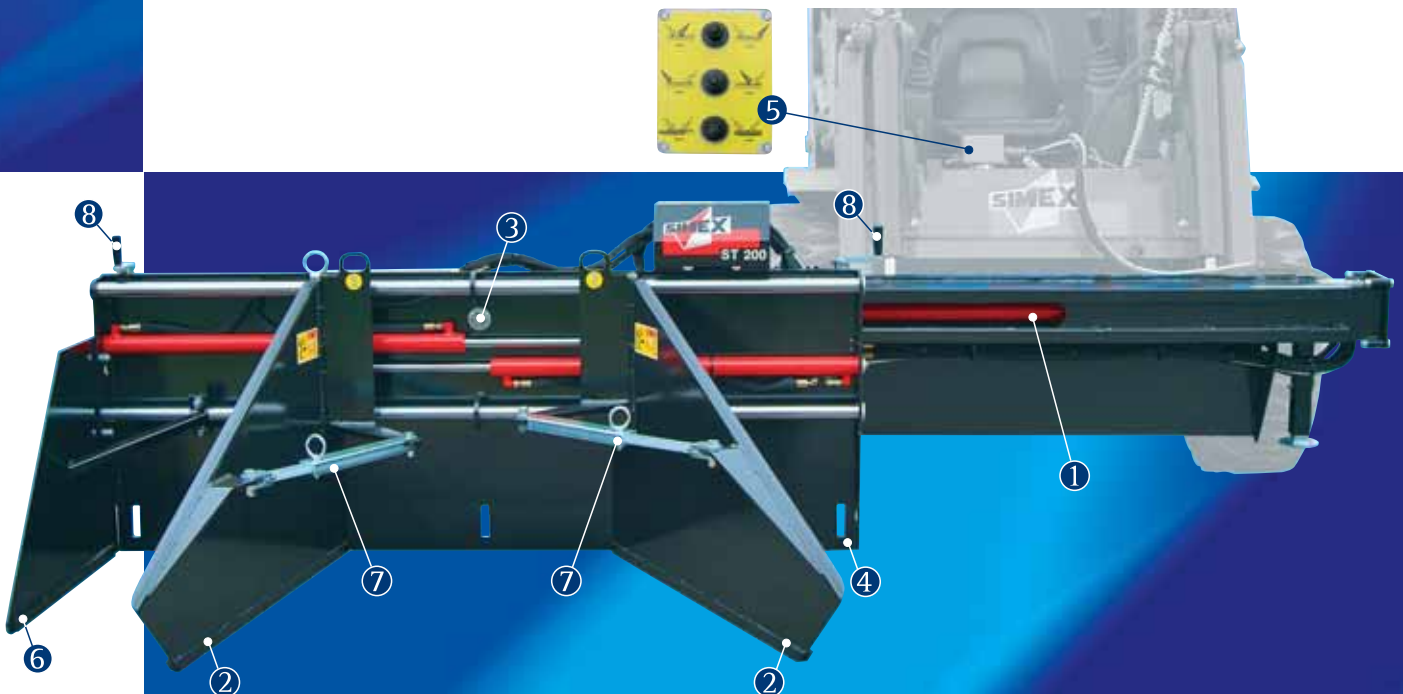

ROAD SIDE ASPHALT SURFACING



Thanks to its side board and right side opposite angling devices to convey asphalt, the Simex asphalt float is easy to use for roadside surfacing.

When following the road surface, the equipment right and left sides can be used as guides.

The result is a wider working road surface, without altering the existing gradient.

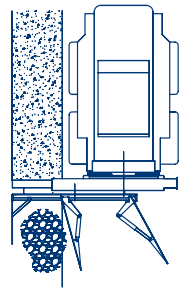

CROSS-SECTION TRENCH FILLING AND ASPHALT FINISHING



The left and right sides are arranged in a V shape to convey asphalt into the trench. The grader blade can be adjusted to set the thickness of the material to be compacted.

Extremely quick working. Compared to traditional working procedures, operating times are reduced by up to 10 times.

Lighter working. Material is placed directly on the ground instead of being carried by the equipment itself.

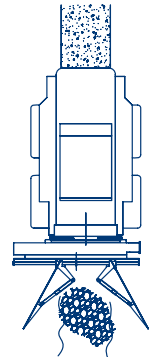

Ideal speed adjustment and accuracy, also in trench filling applications.

SIDEWALK ASPHALT SURFACING

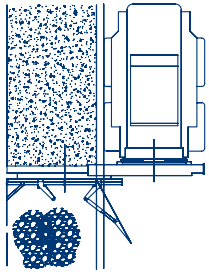

By removing the right side board, the containment board and left side board can be placed against the kerbs. This ensures a perfectly even plane without any rippling, enhanced by an adjustable grader blade.

The machine sides can be hydraulically controlled for easy, instantaneous, step-by-step adjustment of the width of the section to fill.

The ground-level control panel enables the machine in work to avoid obstacles along its path: lampposts, manhole covers, road signs etc.



TECHNICAL SPECIFICATIONS

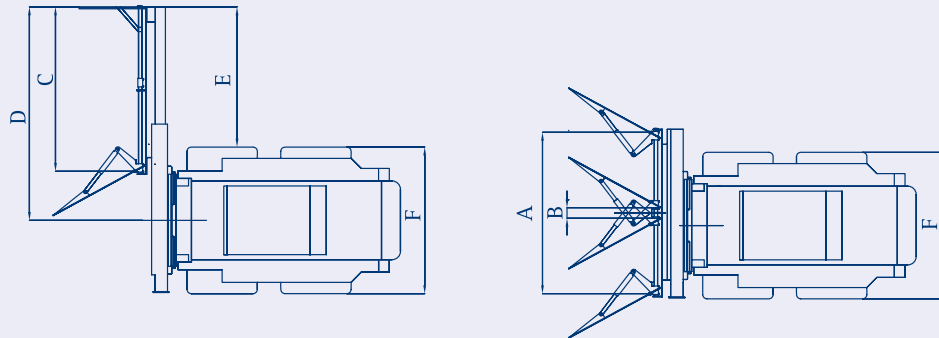

	ST 160	ST 200	
A	1500	1900	mm
B	125	125	mm
C	1560	1960	mm
D	1800	2550	mm
E	1025	1675	mm
F	1550	1750	mm
Asphalt layer adjustment and width	hydraulic		
Asphalt thickness adjustment (independent on the RH and LH sides)	mechanical (screw) or electrical (optional)		
Asphalt thickness	0-100		mm
Side shift	hydraulic		
Transversal inclination	5°		
Average working speed (cross-section trenches)	50-120		m/min
Working weight (1)	570	620	Kg

(1) The user is responsible for checking that the prime mover meets the equipment's specifications and weight requirements.